

Ducting System

Mechanical Installation Guide

To re-order quote part number:	HD0780
Revision:	1.0.0
Revision date:	April 2017

Copyright

Neither the whole or any part of the information contained in nor the product described in this documentation may be adapted or reproduced in any material form except with the prior written approval of Hydronix Limited, hereinafter referred to as Hydronix.

© 2017

Hydronix Limited
7 Riverside Business Centre
Walnut Tree Close
Guildford
Surrey GU1 4UG
United Kingdom

All rights reserved

CUSTOMER RESPONSIBILITY

The customer in applying the product described in this documentation accepts that the product is a programmable electronic system which is inherently complex and which may not be completely free of errors. In doing so the customer therefore undertakes responsibility to ensure that the product is properly installed commissioned operated and maintained by competent and suitably trained persons and in accordance with any instructions or safety precautions made available or good engineering practice and to thoroughly verify the use of the product in the particular application.

ERRORS IN DOCUMENTATION

The product described in this documentation is subject to continuous development and improvement. All information of a technical nature and particulars of the product and its use including the information and particulars contained in this documentation are given by Hydronix in good faith.

Hydronix welcomes comments and suggestions relating to the product and this documentation

ACKNOWLEDGEMENTS

Hydronix, Hydro-Probe, Hydro-Mix, Hydro-Skid, Hydro-View and Hydro-Control are Registered Trade Marks of Hydronix Limited

Hydronix Offices

UK Head Office

Address: 7 Riverside Business Centre
Walnut Tree Close
Guildford
Surrey
GU1 4UG

Tel: +44 1483 468900

Fax: +44 1483 468919

Email: support@hydronix.com
sales@hydronix.com

Website: www.hydronix.com

North American Office

Covers North and South America, US territories, Spain and Portugal

Address: 692 West Conway Road
Suite 24, Harbor Springs
MI 47940
USA

Tel: +1 888 887 4884 (Toll Free)

+1 231 439 5000

Fax: +1 888 887 4822 (Toll Free)

+1 231 439 5001

European Office

Covers Central Europe, Russia and South Africa

Tel: +49 2563 4858

Fax: +49 2563 5016

French Office

Tel: +33 652 04 89 04

Revision history

Revision No	Date	Description of Change
1.0.0	April 2017	First Release

Table of Contents

Chapter 1 Introduction.....	11
1 Ducting System	11
2 Ducting System Vertical	11
3 Ducting System Angled.....	12
4 Installation Method	14
5 Commissioning.....	17
6 Material Flow	18
7 Collecting Calibration Samples	21
Appendix A Document Cross Reference	23
1 Document Cross Reference.....	23

Table of Figures

Figure 1: Ducting System Vertical Overview.....	11
Figure 2: Ducting System Vertical Dimensions.....	12
Figure 3: Ducting System Angled Overview	12
Figure 4: Ducting System Angled Dimensions.....	13
Figure 5: Cut out Dimensions.....	14
Figure 6: Ducting System Vertical Installation	15
Figure 7: Ducting System Angled Installation	15
Figure 8: Ducting System Angled Round Duct Installation	16
Figure 9: Ducting System Vertical Round Duct Installation	16
Figure 10: Installing the Sensor	17
Figure 11: Outlet Baffles (3 supplied)	17
Figure 12: Installing the Baffles.....	18
Figure 13: Ducting System Vertical Material Flow	18
Figure 14: Ducting System Angled Material Flow	19
Figure 15: Checking Material Flow using the Viewing Windows	19
Figure 16: Directing Material Flow	20
Figure 17: Ducting System Vertical Sample Collection	21
Figure 18: Ducting System Angled Sample Collection	21

The Hydronix Ducting Systems are stainless steel units that have been designed to be inserted into ducting to ensure that a stable flow of granular material such as grain, rice and pulses is maintained over a Hydronix Hydro-Mix XT microwave moisture sensor (not supplied).

This Ducting System Installation guide is only valid for model numbers DSV02 and DSA02 onwards. User guides for earlier Ducting System model numbers are available from www.hydronix.com.

1 Ducting System

The Ducting System has been designed to maintain a stable material flow over a Hydronix Hydro-Mix XT Microwave Moisture Sensor. The units are available in two versions: Vertical and Angled. The Ducting System Vertical is designed to be installed in an existing Vertical duct. The Ducting System Angled has been designed to be installed in ducting at between 30-50° to the vertical.

The Ducting system must remain full at all times when the material is flowing with any excess material over flowing. Three different sized outlet baffles are supplied (50mm, 70mm and 100mm) to enable the flow rate to be adjusted to achieve a stable consistent flow.

2 Ducting System Vertical

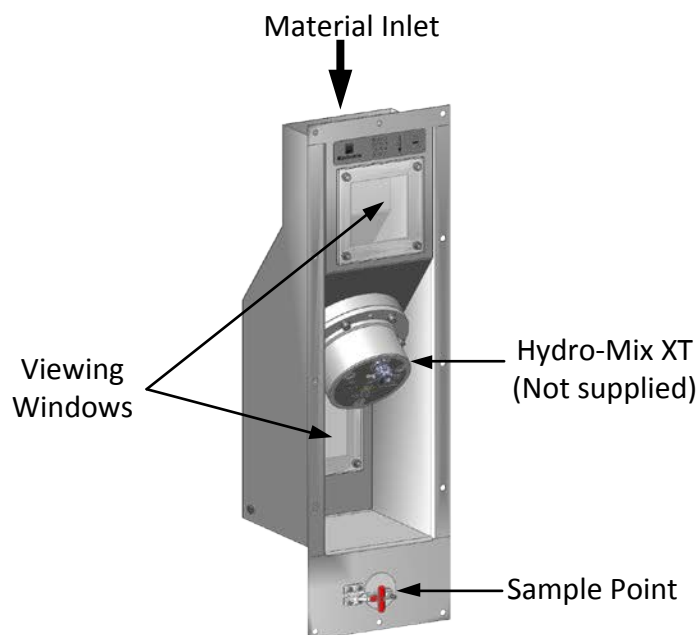

Figure 1: Ducting System Vertical Overview

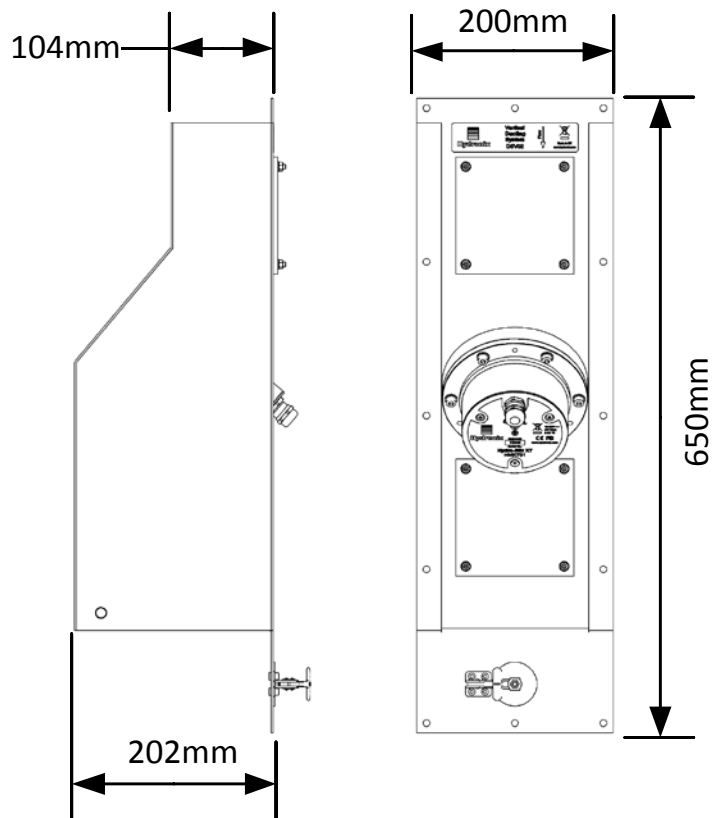

Figure 2: Ducting System Vertical Dimensions

3 Ducting System Angled

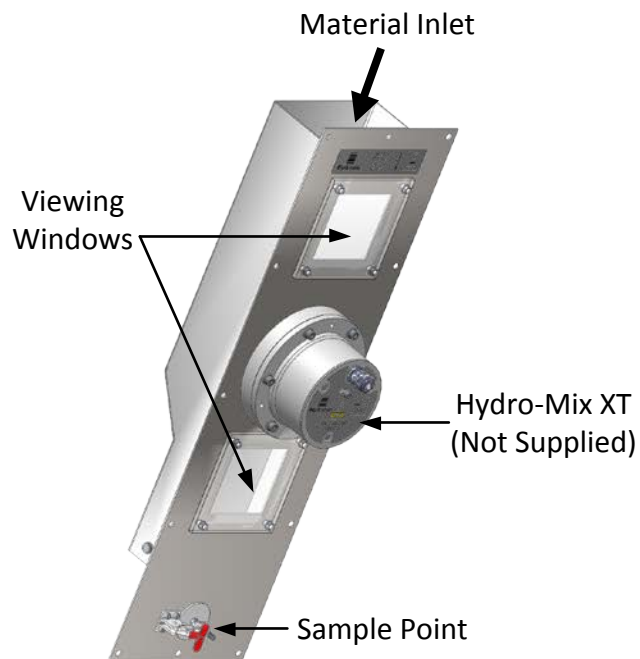

Figure 3: Ducting System Angled Overview

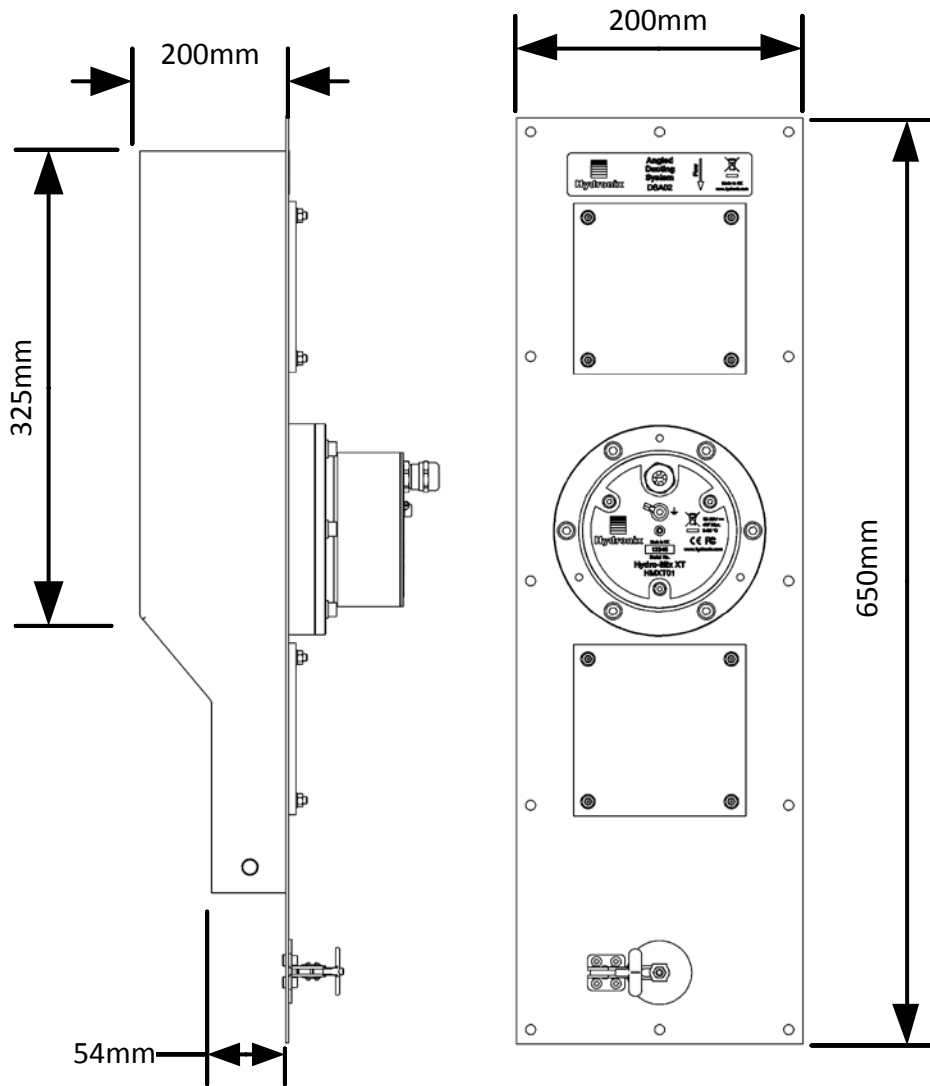

Figure 4: Ducting System Angled Dimensions

4 Installation Method

4.1 Cut Out

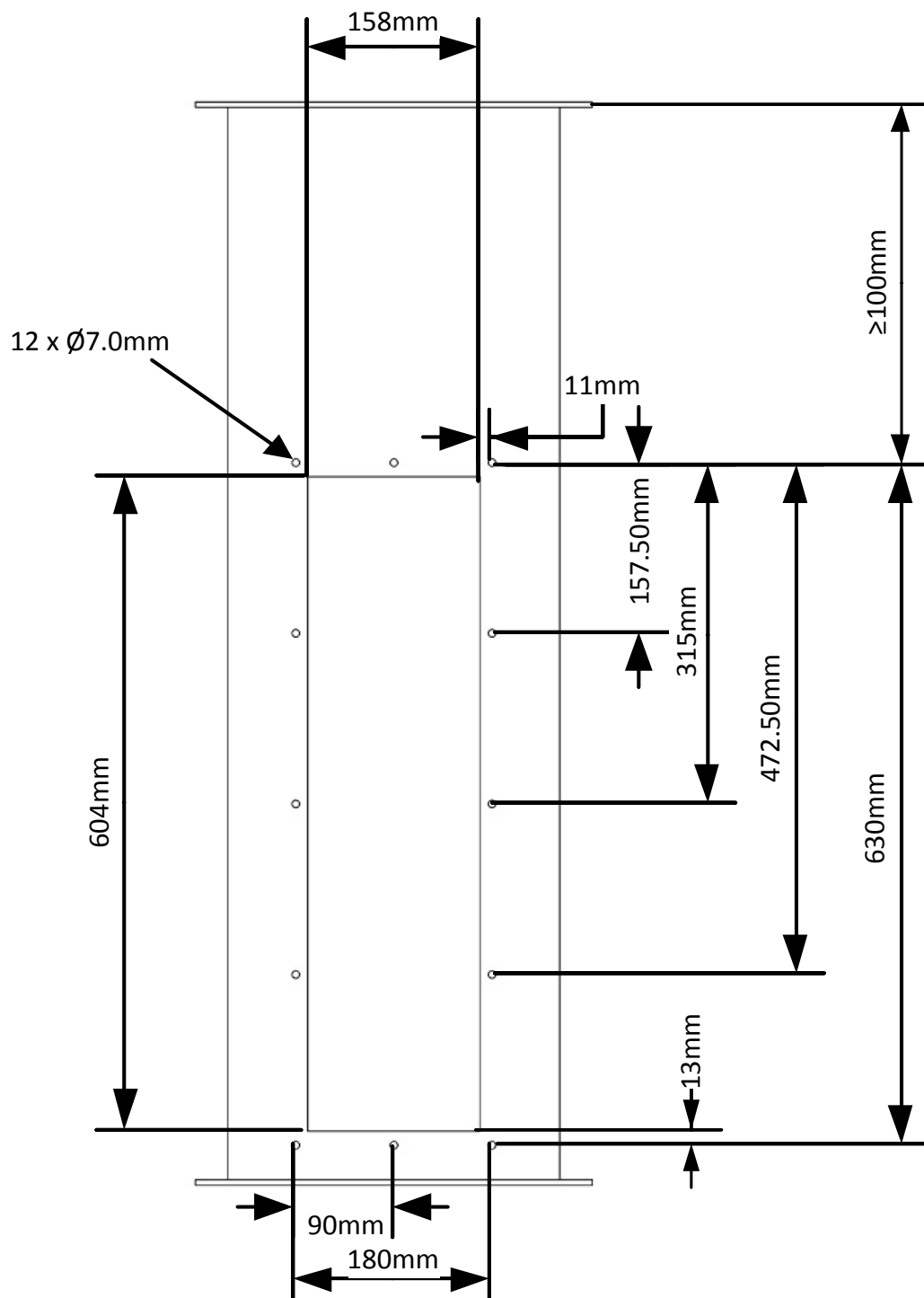

Figure 5: Cut out Dimensions

4.2 Installing the Duct

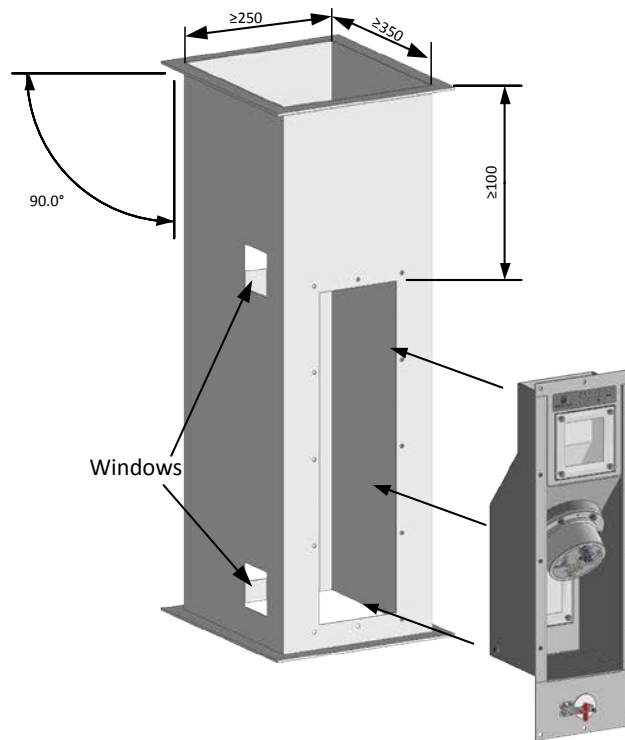

Figure 6: Ducting System Vertical Installation

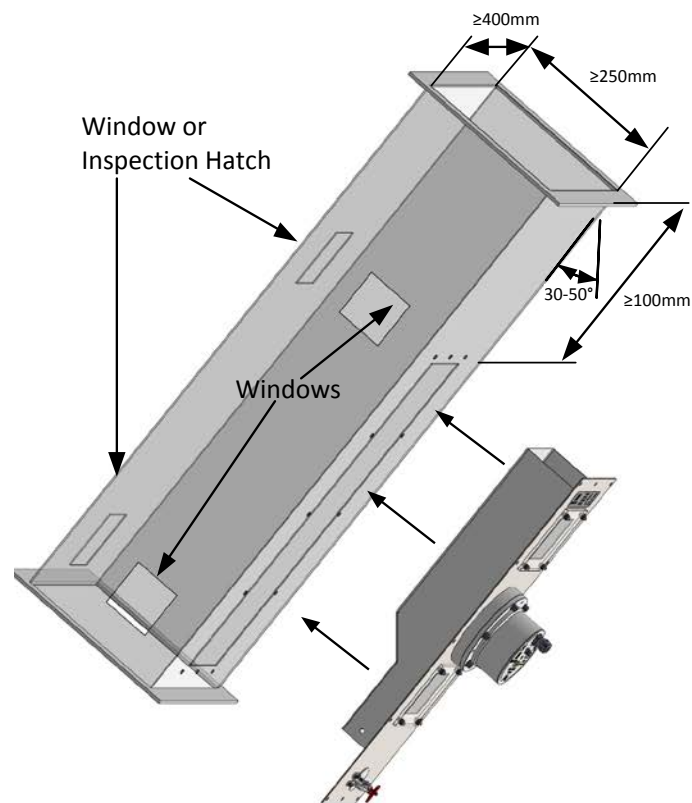

Figure 7: Ducting System Angled Installation

4.3 Installing the Ducting System into a Round Duct

To maintain a stable material flow over the sensor in existing round ducting the following installation methods are recommended.

Ensure all transitions from round to square duct are smooth to avoid material flow disruptions.

4.3.1 Ducting System Angled

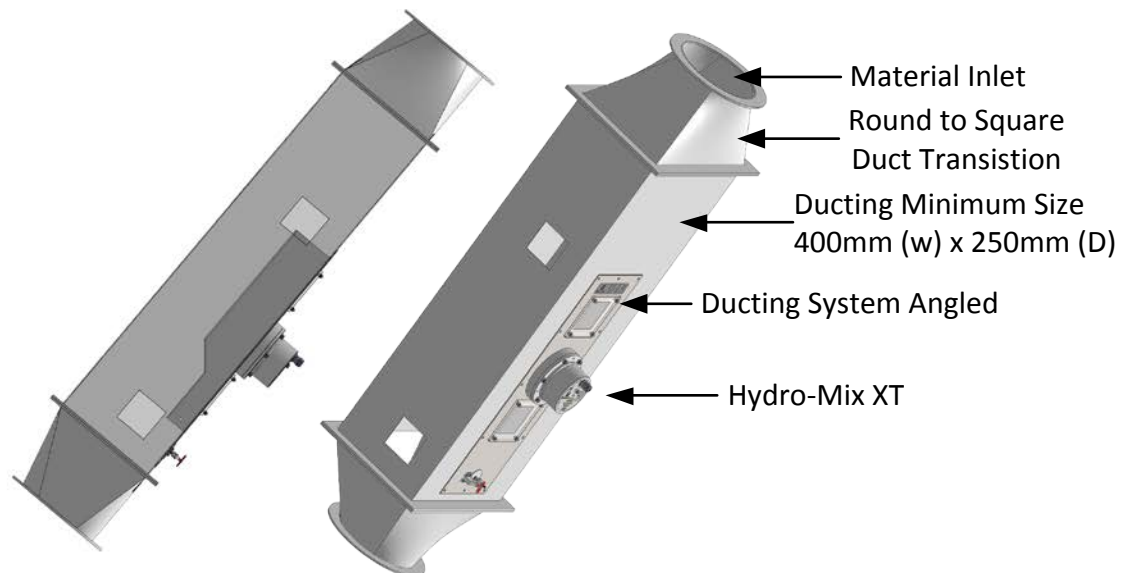

Figure 8: Ducting System Angled Round Duct Installation

4.3.2 Ducting System Vertical

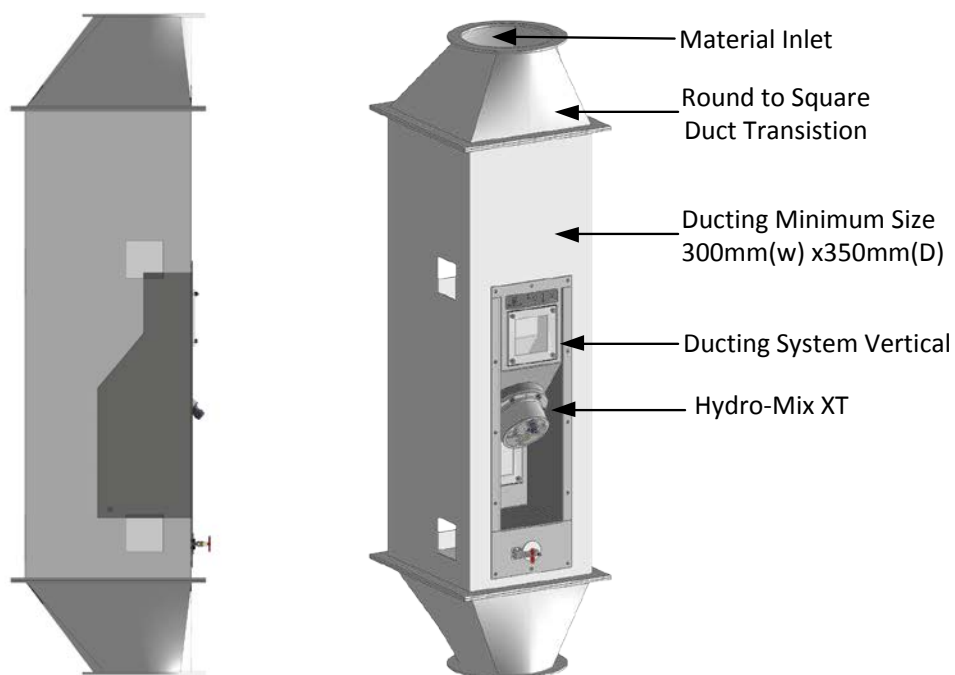

Figure 9: Ducting System Vertical Round Duct Installation

4.4 Installing the Sensor

To install the Hydro-Mix XT sensor ensure that the HMXT Fixing Plate O ring is in position and suitable grease is applied. Insert the sensor ensuring that the HMXT Mounting Flange is in contact with the HMXT Fixing Plate and secure with the 6 HMXT Fixing Plate bolts (Figure 10). Once installed the sensor must be flush with the internal wall of the duct.

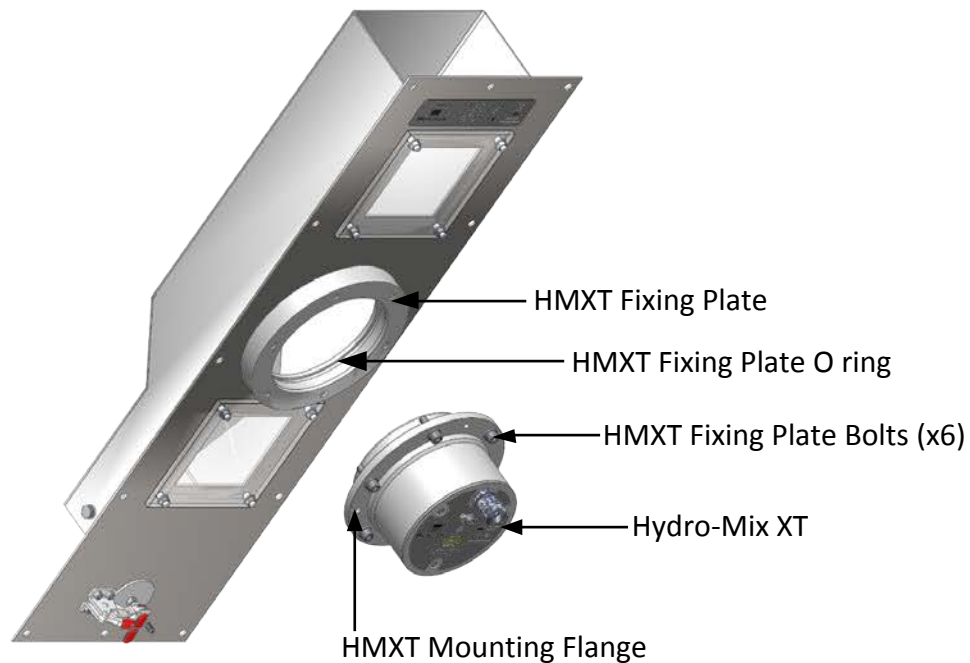

Figure 10: Installing the Sensor

5 Commissioning

5.1 Adjusting the outlet flow rate

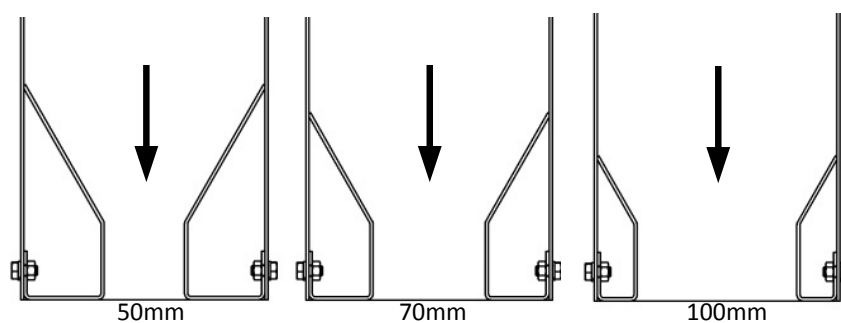

Figure 11: Outlet Baffles (3 supplied)

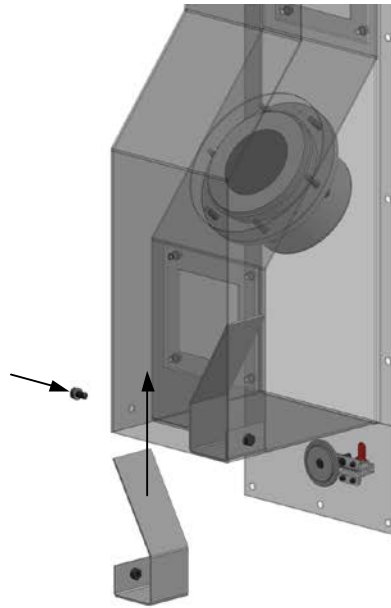

Figure 12: Installing the Baffles

6 Material Flow

6.1 Ideal Material Flow

An ideal material flow will ensure that the Ducting System remains full at all times with excess material overflowing (Figure 14). The outlet of the Ducting system must not be restricted. Enough space must be provided to ensure that the overflowing material is able to flow without restriction.

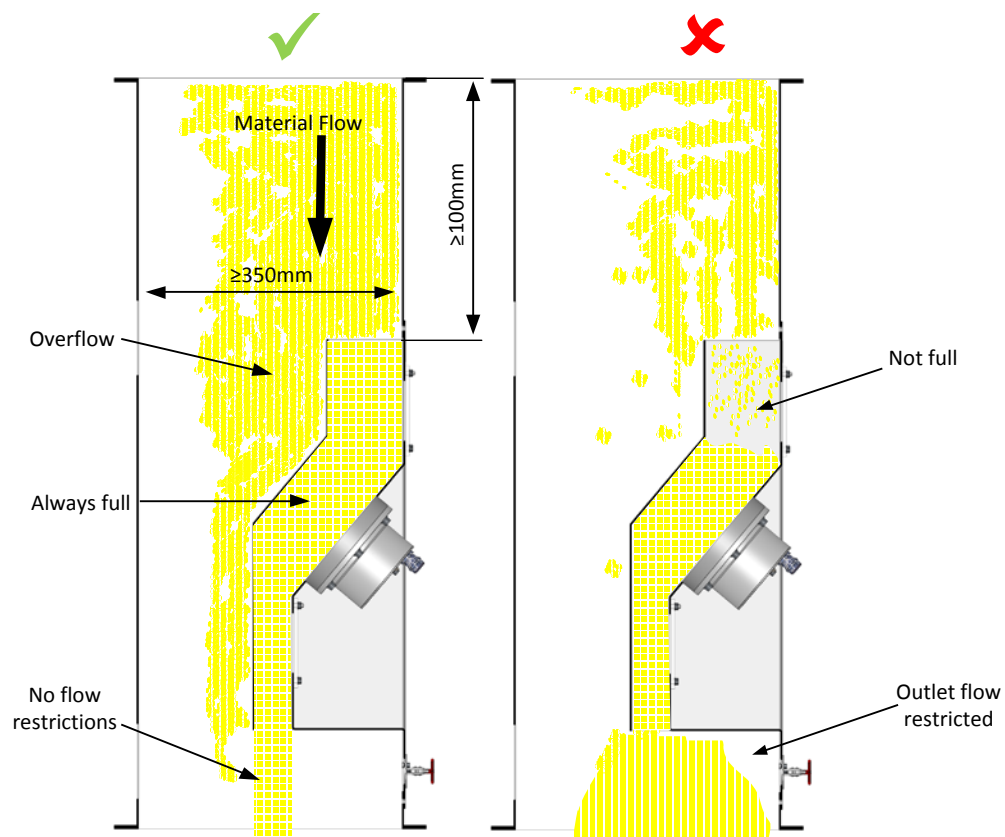

Figure 13: Ducting System Vertical Material Flow

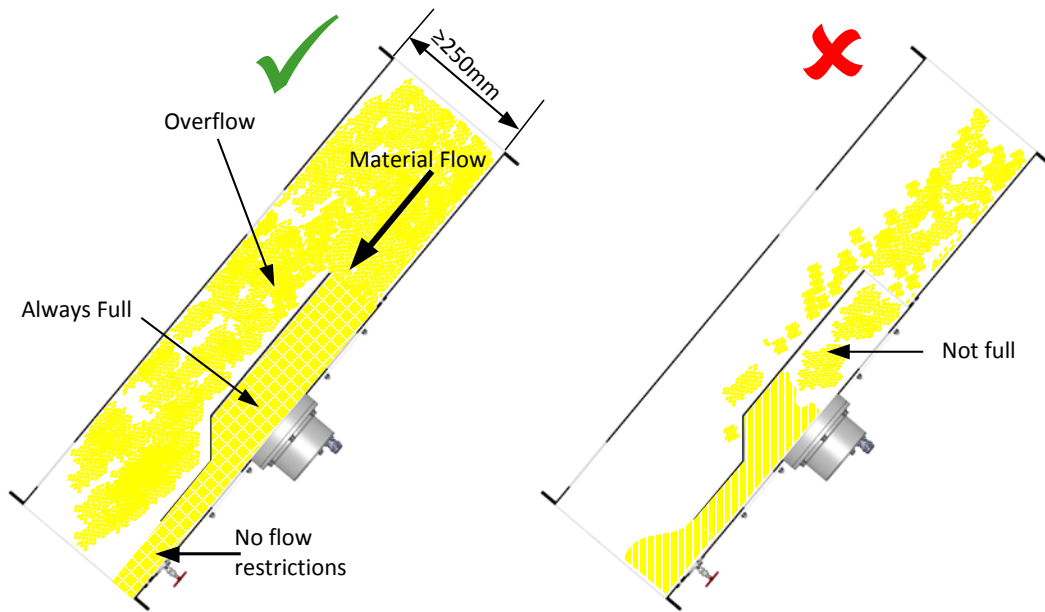

Figure 14: Ducting System Angled Material Flow

6.2 Visual Check on Material flow

A visual check of the two viewing windows will indicate if the material flow is sufficient to keep the Ducting System full at all times.

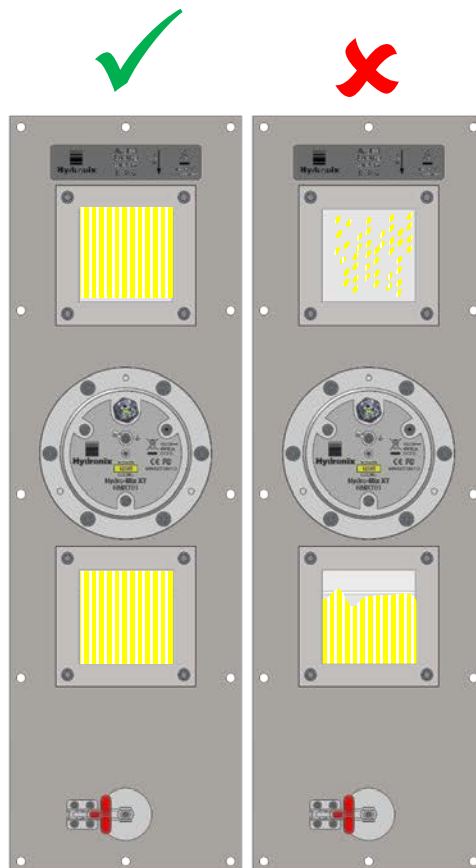

Figure 15: Checking Material Flow using the Viewing Windows

6.3 Directing Material Flow

If the material flow towards the Ducting System is not sufficient to keep it full a diverter might be required to help direct the material (Figure 16). The design and position of the diverter would be specific to the installation.

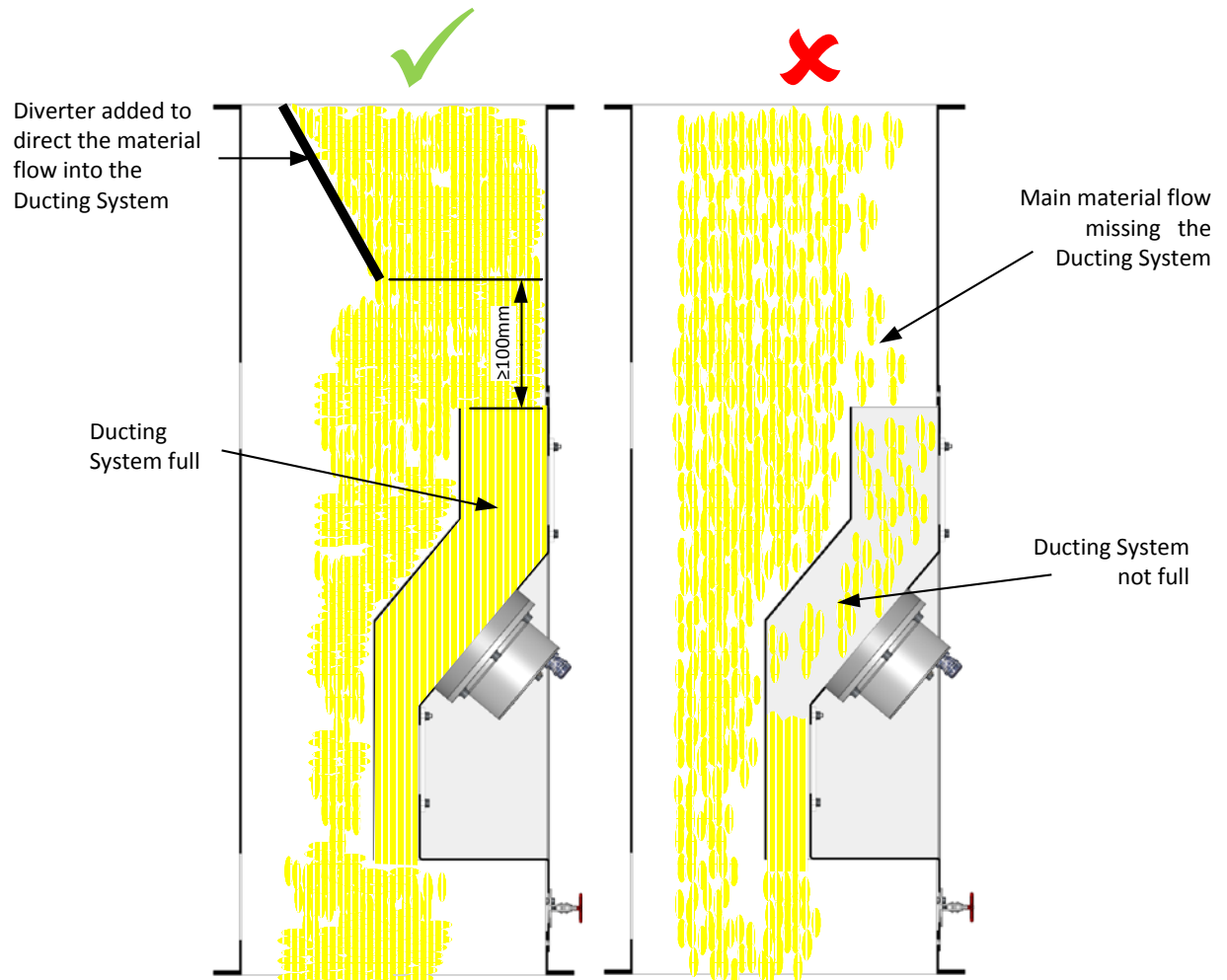

Figure 16: Directing Material Flow

7 Collecting Calibration Samples

For calibration purposes a material sample can be collected using the Sampling point. The Ducting System Vertical (Figure 17) requires the use of the Sampling Tube (Only supplied with the Ducting System Vertical). Material samples from the Ducting System Angled can be collected by opening the Sample Point, no Sampling Tube is required. (Figure 18).



Figure 17: Ducting System Vertical Sample Collection

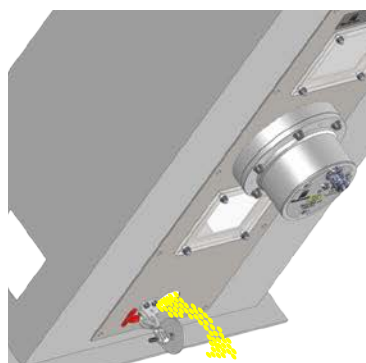

Figure 18: Ducting System Angled Sample Collection

1 Document Cross Reference

This section lists all of the other documents that are referred to in this User Guide. You may find it beneficial to have a copy available when reading to this guide.

Document Number	Title
HD0773	Hydro-Mix XT Mechanical Installation Guide
HD0679	Sensor Configuration and Calibration Guide
HD0678	Sensor Electrical Installation Guide

Index

Baffles	17	Installation	
Calibration		Duct	15
Sampling point.....	21	Sensor	17
Sampling Tube	21	Material Flow	
Dimensions		Diverter.....	20
Cut Out	14	Ducting System Angled.....	19
Ducting System Angled	13	Ducting System Vertical.....	18
Ducting System Vertical	12	Visual Check	19